

High Voltage Quasi-Resonant PWM Controller

General Description

AT1687Z is a highly integrated quasi-resonant (QR) mode PWM control for flyback converter, optimized for high performance, low standby power consumption and cost effective offline flyback converter applications.

The AT1687Z internal valley detector ensures minimum drain voltage switching at QR operation. At low line and heavy loading, it operates in continuous conduction mode (CCM) via an external resistor sets minimum fixed frequency. At high line and normal loading, it operates in QR mode. When light load, it operates in pulse frequency modulation (PFM) mode. When the output power falls below a given level, it enters the burst mode.

The AT1687Z built-in multiple protection with VCC under voltage lockout (UVLO), VCC over voltage protection (OVP), VCC clamp, GATE clamp, internal over temperature protection (OTP), Output over voltage protection, DEM high level protection, cycle-by-cycle current limiting (OCP), over load protection (OLP), and leading-edge blanking (LEB) of the current sensing to prevent circuit damage occurred under abnormal conditions.

The AT1687Z is available in an SOP-10L package and require very few external devices for operation.

< Patent Pending >

Features

- High Voltage Startup Circuit
- VCC Under Voltage Lockout (UVLO)
- VCC Over Voltage Protection (VCC OVP)
- Output Over Voltage Protection by DEM (DEM OVP)
- DEM High Level Protection (DEMHP)
- Cycle-by-Cycle Current Limiting (OCP)
- Over Load Protection (OLP)
- Internal Over Temperature Protection (OTP)
- Leading Edge Blanking (LEB)
- VCC & Gate Voltage Clamped
- 500mA Source/500mA Sink Gate Driver
- Frequency Hopping for Reducing EMI
- SOP-10L Package

Applications

- AC/DC Switching Power Adaptor
- Battery Charger
- Open Frame Switching Power Supply

Pin Configuration

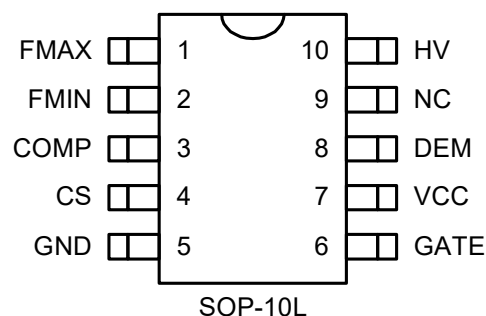

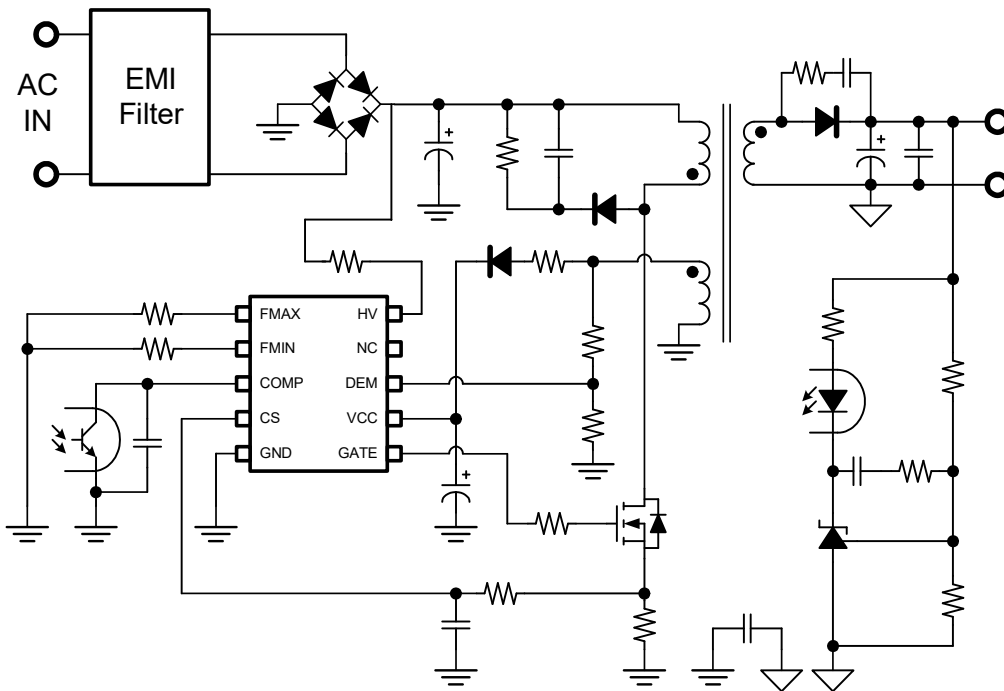
Typical Application Circuit

Function Pin Description

Pin No.	Pin Name	Description
1	FMAX	Maximum frequency programming pin. This pin connecting a resistor to ground for setting maximum switching frequency.
2	FMIN	Minimum frequency programming pin. This pin connecting a resistor to ground for setting minimum switching frequency.
3	COMP	Voltage Feedback pin. This pin connecting an opto-coupler to monitor output for regulation control loop.
4	CS	Current Sense pin. This pin sense primary MOSFET current.
5	GND	Ground.
6	GATE	PWM Signal Output pin. This pin output to drive the external power MOSFET.
7	VCC	Power Supply.
8	DEM	This pin is for valley switching detector of the auxiliary winding signal and also used for output over voltage protection.
9	NC	Unconnected pin.
10	HV	High Voltage pin. This pin connecting to Bulk cap capacitor via resistors to be a high voltage start-up current source.

Ordering and Marking Information

Order Number	Package	Top Marking
AT1687ZSPA	SOP-10L	AT1687Z

Note: Aplustek products are compatible with the current IPC/JEDEC J-STD-020 requirement. They are halogen-free, RoHS compliant and 100% matte tin (Sn) plating that are suitable for use in SnPb or Pb-free soldering processes.

Protection Mode

Part Number	OLP	VCC OVP	DEMOVP	DEMHP	Int. TSD
AT1687Z	Auto	Latch	Latch	Latch	Auto

Function Blocks

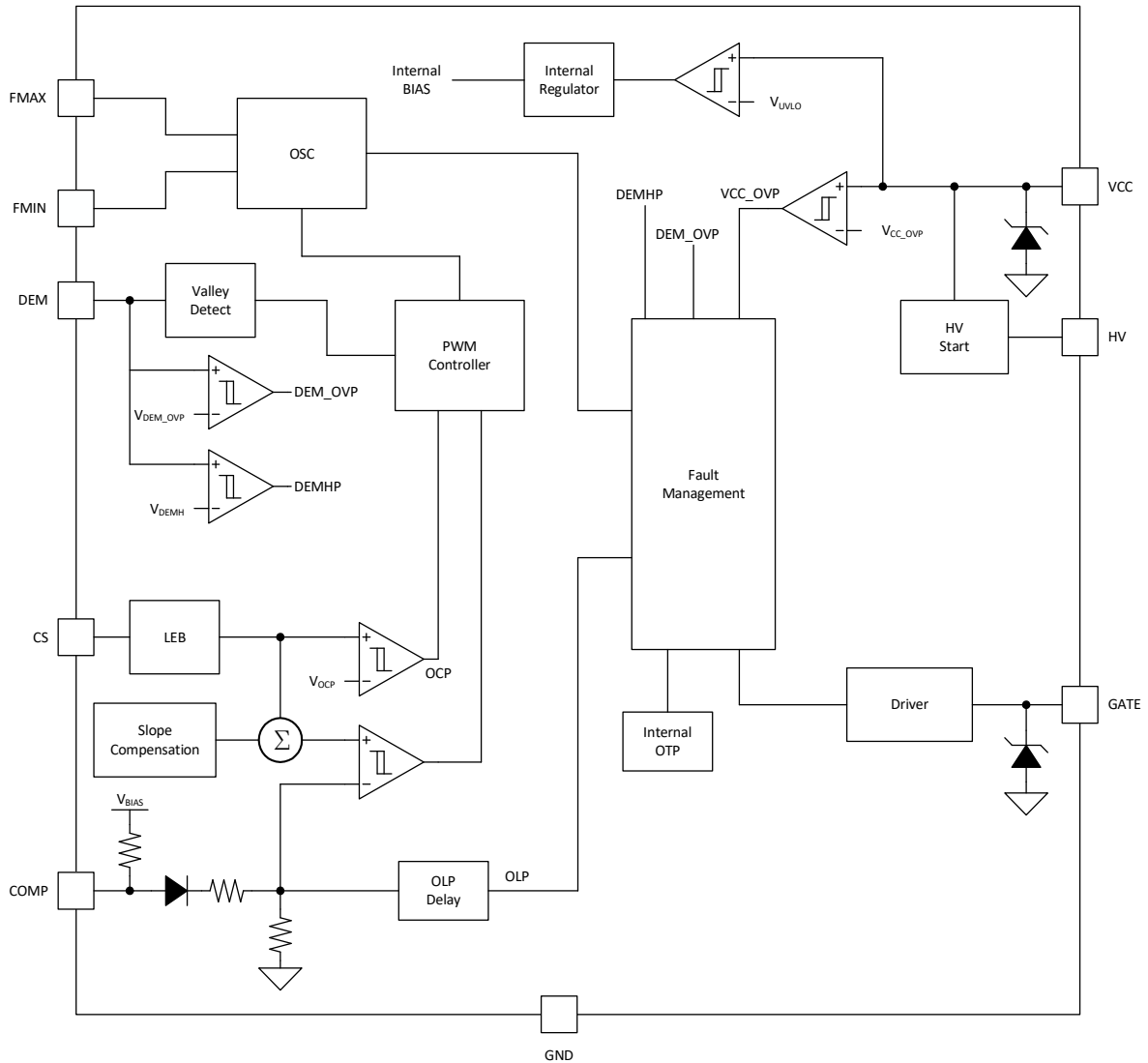



Absolute Maximum Ratings

(Note1)

Supply Input Voltage, VCC	-----	-0.3V to +32V
High-Voltage Pin, HV	-----	- 0.3V to +700V
FMAX, FMIN, COMP, CS, DEM	-----	-0.3V to +7V
GATE	-----	-0.3V to +20V
Storage Temperature Range	-----	-65°C to +150°C
Junction Temperature	-----	-40°C to +150°C
Lead Temperature Range(Soldering 10sec)	-----	260°C
ESD Rating		
HBM(Human Body Mode, Except HV Pin)	-----	4KV
HBM(Human Body Mode, HV Pin)	-----	1.5KV
MM(Machine Mode)	-----	400V

Thermal Characteristics

Package Thermal Resistance (Note3)

SOP-10L θ_{JA}	-----	120°C/W
SOP-10L θ_{JC}	-----	45°C/W

Power Dissipation, PD @ TA = 25°C

SOP-10L	-----	1W
---------	-------	----

Electrical Characteristics

(V_{CC} = 12V, T_A = +25°C unless otherwise specified.)

Parameter	Symbol	Test Conditions	Min	Typ	Max	Units
Supply Input Section						
Operating Voltage			8	--	27	V
Power On Voltage	VCC_on		13.5	14	14.5	V
Holdup Voltage	VCC_hold	I _{HV} >1mA	8	8.5	9	V
Power Off Voltage	VCC_off		7	7.5	8	V
Reset Voltage	VCC_rst		6	6.5	7	V
Over Voltage Protection Voltage	VCC_ovp		27	28.5	30	V
Internal Zener Clamp	VCC_clamp	I _{CC} >2*I _{CC_op}	--	31	--	V
Startup Current	ICC_start		200	270	350	uA
Normal Operating Current	ICC_op	C _L =1nF	--	1.3	--	mA
Burst Mode Operating Current	ICC_bs	V _{COMP} <V _{COMP_bs}	--	0.35	--	mA
COMP Pin Section						
COMP Pull High Impedance	ZCOMP		--	40	--	kΩ
Open Loop Voltage	V _{COMP_o}	COMP Open	--	5	--	V
Over Load Protection Voltage	V _{COMP_olp}		--	4.4	--	V
Over Load Protection Debounce Time	T _{deb_olp}		--	65	--	ms

Parameter	Symbol	Test Conditions	Min	Typ	Max	Units
High Voltage Section						
High-Voltage Current	IHV_on	VCC>1V	2.5	3	3.5	mA
Initial High-Voltage Current	IHV0_on	VCC=0V	--	0.67	--	mA
High-Voltage Off Current	IHV_off	VHV=600V,VCC>VCC_on	--	--	20	uA
Oscillation Section						
Minimum Frequency	Fosc_min	Fmin=100kΩ to GND	61	65	69	kHz
Maximum Frequency	Fosc_max	Fmax=75kΩ to GND	81.5	87	92.5	kHz
Fmin; Fmax Resistor Range			39	--	150	kΩ
Nominal Voltage of Fmin/Fmax			1.2	1.25	1.3	V
Green Frequency	Fosc_gr	VCOMP_bs<VCOMP<VCOMP_gr	--	24	--	kHz
COMP Threshold for Frequency Reduction	VCOMP_f	Fosc<Fosc_min	--	2.2	--	V
COMP Voltage for Green Frequency	VCOMP_gr	Fosc=Fosc_gr	--	2	--	V
COMP Threshold for Zero Duty	VCOMP_bs		--	1.6	--	V
Frequency Hopping Range		Fosc=Fosc_min	--	+5	--	%
Current Sense Section						
Delay to Output			--	--	100	ns
Leading Edge Blanking Time	t_leb	VCS>1.1V	--	350	--	ns
Minimum On Time	ton_min		--	710	--	ns
CS Threshold at Max Duty	VCS_max	Fosc=Fosc_min	0.885	0.9	0.915	V
Input Impedance	ZCS		1	--	--	MΩ
Soft Start Time	tss		--	0.5	--	ms
GATE Section						
Maximum Duty Cycle	Dmax	Max Frequency	79	85	91	%
Output Voltage Low	Vol	VCC=15V, I _o =20mA Sinking	--	0.12	0.25	V
Output Voltage High	Voh	VCC=15V, I _o =20mA Sourcing	9	11	--	V
Rising Time	tr	CL=1nF,Vgate from 2V to 6V	--	88	--	ns

Note 1. Exceeding these limits may impair the life of the device. Exposure to absolute maximum rating conditions for long periods may affect device reliability.

Note 2. θ_{JA} is measured with the component mounted on a high effective thermal conductivity test board in free air. The exposed pad of the package is soldered directly on the PCB.



Parameter	Symbol	Test Conditions	Min	Typ	Max	Units
Falling Time	tf	CL=1nF,Vgate from 6V to 2V	--	10	--	ns
Gate Voltage Clamping	Vgate_clamp	VCC=27V	12	14	16	V
DEM Pin Section						
Negative Clamp Voltage		Source Current=100uA	--	-0.5	--	V
Positive Clamp Voltage		Sink Current=100uA	--	5.15	--	V
Valley Detection Voltage	Vvalley		--	0.1	--	V
DEM OVP (sampling detection)	VDEMOVP		3.135	3.3	3.465	V
DEM High Level Protection Voltage(continuous detection)	VDEMHP		3.325	3.5	3.675	V
Blanking Time for DEM OVP Sense after GATE off	tbk_demovp		--	2.5	--	us
TSD Section						
Internal Thermal Protection	TSD_int		--	140	--	°C
Fault Section						
Fault Recycle Time	tcyc_fault		--	1	--	s
Fault Debounce Time (Exclude OLP & Output OVP)	tdeb_fault		--	75	--	us

Note 1. Exceeding these limits may impair the life of the device. Exposure to absolute maximum rating conditions for long periods may affect device reliability.

Note 2. θ_{JA} is measured with the component mounted on a high effective thermal conductivity test board in free air. The exposed pad of the package is soldered directly on the PCB.

Package Information

SOP-10L

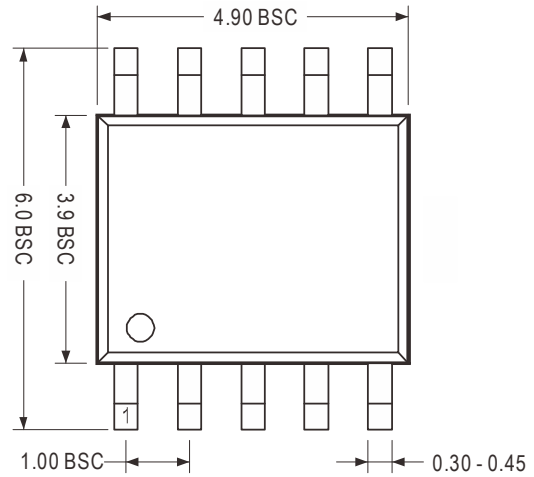
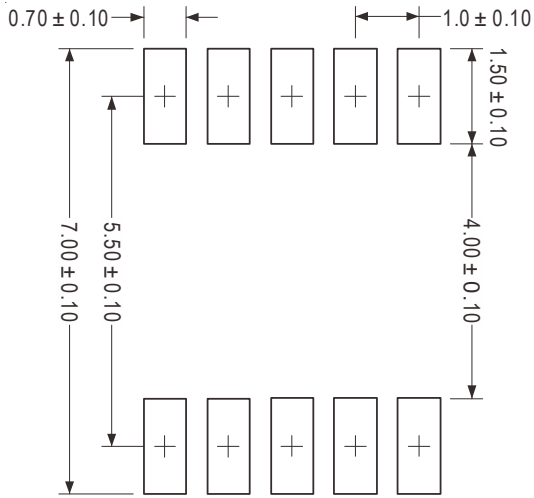

Recommended Solder Pad Layout

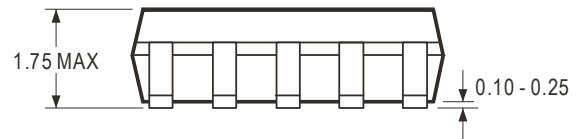
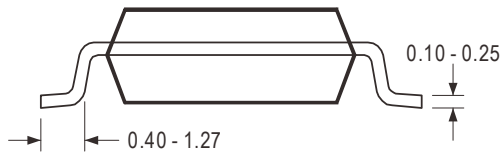

Note

1. Package Outline Unit Description:

BSC: Basic. Represents theoretical exact dimension .

MAX: Maximum dimension specified.

MIN: Minimum dimension specified.

REF: Represents dimension for reference use only. The value is not the device specification.

TYP: Represents as a typical value. The value is not the device specification.

2. All linear dimensions are in Millimeters.